



RefaceSupplies
.com

PEEL & STICK REFACE INSTALLATION GUIDE FOR CABINETS

May 2016 Version



PEEL STICK LAMINATES | DOORS & DRAWERS | TOOLS & ACCESSORIES

P (321) 418-7181 | F (407) 650-2612 | SALES@REFACESUPPLIES.COM | REFACESUPPLIES.COM

KITCHEN | BATH | GARAGE | ACCENT WALL | APARTMENT | SIGN | OFFICE | COMMERCIAL

PEEL & STICK REFACE INSTALLATION GUIDE FOR CABINETY

TABLE OF CONTENTS

SECTION 1: QUALIFYING A REFACE PROJECT (INSPECTION OF CABINETY)	2
IDENTIFY THE CABINET TYPE.....	2
DELAMINATION.....	3
WATER DAMAGE.....	3
ADHESION SURFACE QUALITY.....	4
FLAT JOINT LINES.....	4
ESTIMATING QUANTITY OF LAMINATE NEEDED.....	5
SECTION 2: SELLING REFACE	5
MOLDINGS.....	6
DOORS & DRAWERS	6
HARDWARE	7
SECTION 3: MEASURING	8
MEASURING FOR DOOR & DRAWER SIZES	8
MEASURING FOR HINGES.....	9
SECTION 4: PREPARING CABINETS FOR REFACING	10
EMPTY CABINETS.....	10
CLEANING.....	10
LEVELING OF JOINT SURFACES.....	11
PAD OUTS.....	11
SANDING OF ADHESION SURFACE	12
SECTION 4: PREPARING CABINETS FOR REFACING	12
APPLICATION OF LAMINATE	12
TRIMMING.....	15
FINISHING OF THE EDGES	16
SECTION 6: DOOR & DRAWER FRONT INSTALLATION	16
APPLYING HINGES TO DOORS	16
HANGING THE DOORS	17
SECTION 7: HARDWARE	18
MARKING FOR HARDWARE.....	18
DRILLING FOR HARDWARE.....	19
SECTION 8: THE FINISHING TOUCHES	19
HINGE ADJUSTMENTS.....	19
PLACEMENT OF BUMPERS	20
CLEANUP	20

PEEL & STICK REFACE INSTALLATION GUIDE FOR CABINETS

SECTION 1: QUALIFYING A REFACE PROJECT (INSPECTION OF CABINETS)

It is important to know that Reface isn't going to be the right fit for every situation. In fact, Reface is a good fit, on average, only 1/3 of the time. Though Refacing can be quite profitable, you can get into a lot of trouble really fast if you start a job without first thoroughly inspecting what you are Refacing. This section outlines the most common things to look for before starting a job.

IDENTIFY THE CABINET TYPE _____

There are 2 types of cabinets: **Face Frame** and **Euro**. It is important to know which one you are working with as the cabinet style will determine everything from hinge style to the amount of Laminate you will need to order. Below is a diagram of both types of cabinets:

Euro Style Cabinets:

- Have flat sides, tops, & bottoms.
- The fronts are thin. Usually 3/4 of an inch thick.
- The doors will always cover the front of the cabinet.
- There is no center divider between doors.
- Hinges will mount on the inside wall of the cabinet.

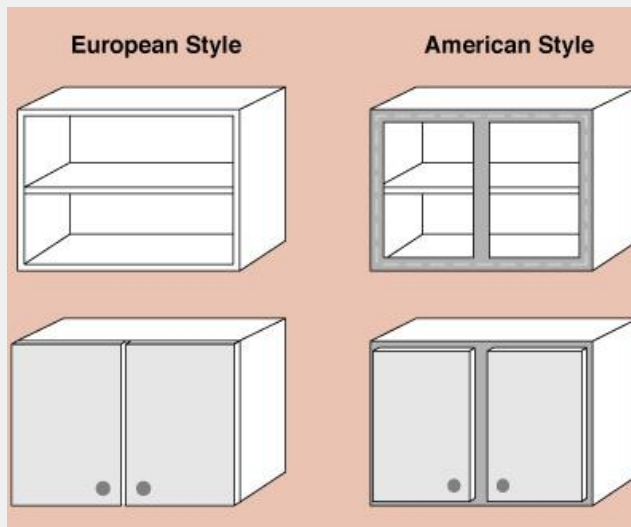

Face Frame Cabinets:

- Usually have recessed tops and bottoms.
- The fronts are thicker. The size may vary by manufacturer but standard size frame is 2 inches wide.
- The doors can either cover the frame completely or the frame can show.

Once you have identified the type of cabinet you want to reface, you will be able to calculate the amount of laminate you need as well as the type of hinge, and even the size tolerance of the doors.

Euro cabinets will almost always need laminating on the bottoms of the upper cabinets. The tops of the cabinets, though flat, do not usually get laminated as they are never seen. Be sure to order enough laminate to cover the bottoms which will be covered in depth in Section 2 of this Installation Guide.

Face Frame cabinets, unless they are completely flat on the bottom, do not get laminated on the top or bottom. You will have to pad out the sides with 1/8—1/4 inch plywood before refacing.

PEEL & STICK REFACE INSTALLATION GUIDE FOR CABINETRY

DELAMINATION

It isn't important what shape the old doors are in because they will be replaced. However, the cabinet boxes must be in good sound condition. It is important to remember that with refacing, the adhesion is only as strong as the surface it is being applied to. You will need to look for loose laminate or veneer, especially around the corners and edges. If you find issues upon inspection make sure it is possible to properly re-attach these loose pieces before you take on the reface project. Super glue, or gorilla glue will become your best friend in terms of overcoming delamination issues. Be sure to keep some in your tool bag at all times. Below are some samples of delamination so you have an idea what to look for:



DELAMINATING FACE



DELAMINATING SIDE



CHIPPED CORNER

WATER DAMAGE

ANY evidence of water damage is an automatic sign that refacing is not the correct fix for the job. Due to the potential health hazards concerning mold you should never reface any cabinet that shows signs of water damage. If you find swelling, blistering, flaking, dampness, or mold itself it is best to have the damaged product removed as soon as possible. Mold poses a very serious health risk to those who live in an environment where it is growing. Refacing can be done once the damaged boxes have been replaced. Please review the pictures below for examples of water damage:



OLD DAMAGE W/MOLD



DAMPNESS & SWELLING



UNDER CABINET LEAKS



SWELLING

PEEL & STICK REFACE INSTALLATION GUIDE FOR CABINETS

ADHESION SURFACE QUALITY

You will want to check the existing surfaces for imperfections that will possibly telegraph through when refacing. It can't be stressed enough that your reface adhesion is only as good as the surface you are adhering to.

When inspecting your cabinets you want to look for things like flaking paint, loose laminate or paper coverings (typically used on the sides of cheaper cabinets). If you see something questionable be sure to have a plan for fixing the issue before starting the reface. Some things like rough paint can be fixed with a little sanding using a hand or orbital sander. Other things like dirt and grease can be cleaned off with soap and water, or even a degreaser if necessary.

For reface to be a good option the "Bones" of the cabinets need to be in great shape structurally. You do not want to reface cabinets that are sagging on the top or bottom, or cabinets that are bowed on the sides. Reface is only cosmetic so if you are in doubt as to whether a cabinet is good enough structurally to reface you should probably error on the side of caution and replace.

FLAT JOINT LINES

One of the last things you should look for in cabinet reface quality isn't necessarily a deal breaker but it can mean a big difference in the time it takes to prep a job. When full facing a run of cabinets, (using one continuous sheet to cover multiple cabinets with one piece of laminate) the fronts of multiple cabinets should line up to create a transition that feels smooth to the touch when running your fingers across the joint of any two cabinets. If a gap exists it will need to be filled with wood putty, or Bondo, then sanded smooth before applying the laminate. The same goes for cabinets that have edges that stick out proud of the adjoining face. These joints will need to be sanded, or re-aligned if possible, before applying laminate so as not to end up with an air gap that will show through the laminate. There is no real guide for what is un-acceptable in this scenario. Use your best judgment to determine if the reward is worth the extra effort in prep work.

PEEL & STICK REFACE INSTALLATION GUIDE FOR CABINETRY

SECTION 2: SELLING REFACE

ESTIMATING QUANTITY OF LAMINATE NEEDED

When determining how much laminate you will need for your job you must first determine what you are laminating. There are two types of cabinets as discussed in section 1 (Face Frame, & Euro). See sample (A) below for a guide on how to measure for Face Frame. See Sample (B) on the next page, (6), for instructions on how to measure for Euro Style.

Sample A: (Light boxes under cabinets do not get laminated when refacing, only sides and faces)



When measuring for refacing it is assumed that the face of the boxes will be laminated in full sheets with excess cut out and discarded. This eliminates lines that are created over joints. However, when laminating with wood grain colors you may want to cut the material into strips so that the styles and rails are laminated in a way that makes the product look more like real wood (vertical grain on stiles, & horizontal on rails). If you subscribe to the idea that time is money then you will understand that the cost of material spent to full face vs the significantly longer time it takes to piece together small pieces is a zero sum game.

To figure out how much laminate to order you will need to find out the **linear** footage (LF) of the exposed surfaces on both the upper & lower cabinets and add them together. Be sure to count the sides of the cabinets and the backs of peninsulas when figuring out the footage. Once you have figured out the Linear footage you will convert the number into linear yards (LY) by dividing the total LF by 3. Next you will round up to the next whole number. This will give you the amount of material you should order. See example below.

Assume your cabinets, including sides, came up to 25 Linear feet (measuring horizontally).

PROCESS: **Step 1)** $25 \text{ LF} \div 3 = 8.33$ **Step 2)** round up to the next LY, **(8.33 LY = 9 LY)**

Peel & Stick laminates can be ordered in the following quantities: **(3LY), (10LY), & (30LY)**

PEEL & STICK REFACE INSTALLATION GUIDE FOR CABINETS

MOLDINGS

At this time, RefaceSupplies.com doesn't sell moldings. However, watch for updates on our website for molding options and pricing coming soon. When available, moldings will be sold in 8' sticks.

- * 1/4 Round
- * Scribe Mold
- * Crown

DOORS & DRAWERS

For estimating purposes you just need to count the number of doors and drawers. If you have a corner cabinet where the door is pieced together with a hinge on a 90 degree angle, be sure to count it as two separate doors. Below is an example of a small kitchen. Count the doors and drawers. The answer key is at the bottom of the page.

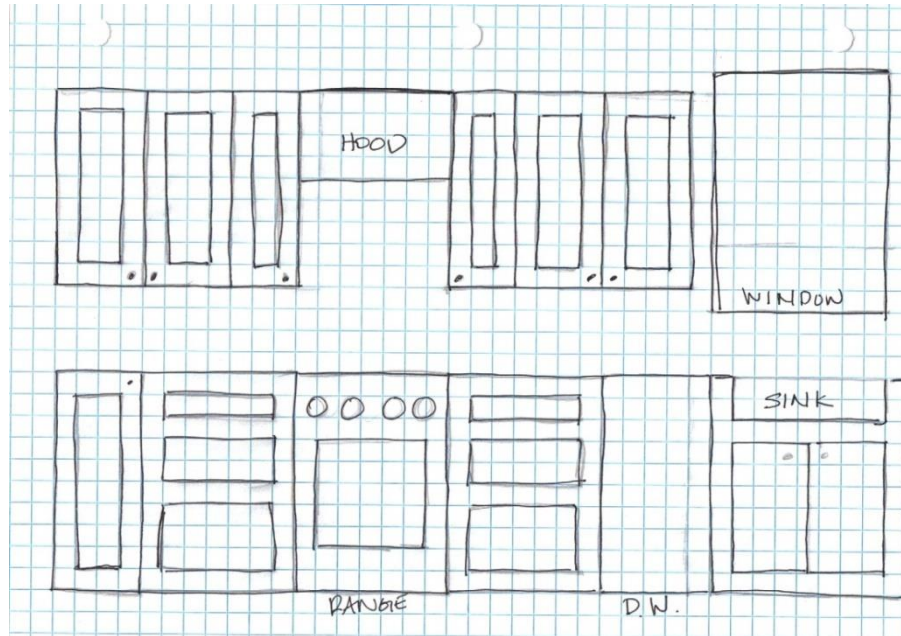

DOORS = _____ DRAWERS = _____

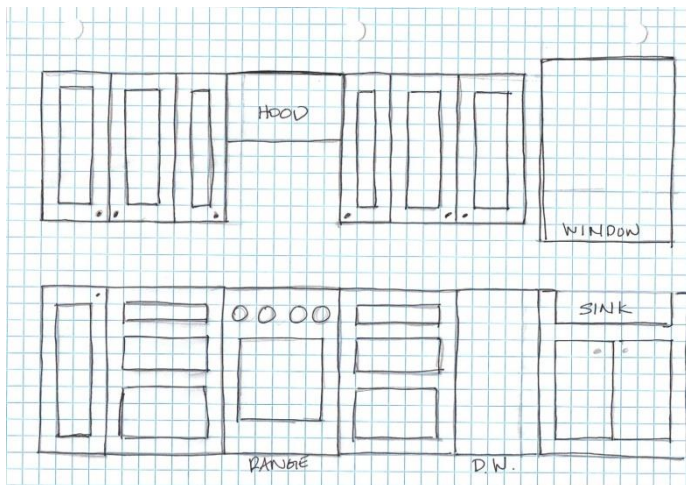

KEY

DOORS = 9 (6 upper, 3 lower)

DRAWER FRONTS = 6 (3 left, & 3 right of range)

7 if the sink has a false front instead of farm sink shown.

PEEL & STICK REFACE INSTALLATION GUIDE FOR CABINETRY

HARDWARE

At this time, RefaceSupplies.com doesn't sell hardware. However, watch for updates on our website for hardware options and pricing coming soon. When available, we intend to carry a small line of basic hardware. Most often hardware is chosen by touch and feel as it is a very tactile product. For this reason it is suggested that a customer find their own hardware to have installed as there are endless selections to choose from. The hardware is the jewelry on any cabinet remodel. Just like jewelry is an expression of your style, so is your hardware. Express yourself.



PEEL & STICK REFACE INSTALLATION GUIDE FOR CABINETY

SECTION 3: MEASURING

MEASURING FOR DOOR & DRAWER SIZES

It is important to be VERY accurate when measuring your doors & drawer fronts. The best method is to count like sizes together. For example, you might want to count all of your upper doors first as they are mostly going to be the same heights. Then you may want to count the lower doors because they too will be mostly the same in height to each other.

Drawer fronts tend to be of similar width because they often stack on top of one another. Drawers are also grouped together because, unlike doors, the width measurement is usually bigger than the height. There is another reason why drawers should be measured together as well. If you are laminating using a directional pattern, (like woodgrain), you may want to control the direction of the pattern. For this reason you want to be sure to measure to notate pattern direction on the doors & drawer fronts separately.

Measurements for doors & drawers can be as accurate as a 1/32 of an inch. However, it is more common that you will measure to the nearest 1/16 of an inch. Due to the fact that all orders must be placed using a decimal system, a conversion chart has been provided below for use when converting from fractions to decimals. Additionally, for those who may not be used to using a tape measure, a sample tape measure

FRACTIONS TO DECIMALS	
1/32 = 0.03125	17/32 = 0.53125
1/16 = 0.0625	9/16 = 0.5625
3/32 = 0.09375	19/32 = 0.59375
1/8 = 0.125	5/8 = 0.625
5/32 = 0.15625	21/32 = 0.65625
3/16 = 0.1875	11/16 = 0.6875
7/32 = 0.21875	23/32 = 0.71875
1/4 = 0.25	3/4 = 0.75
9/32 = 0.28125	25/32 = 0.78125
5/16 = 0.3125	13/16 = 0.8125
11/32 = 0.34375	27/32 = 0.84375
3/8 = 0.375	7/8 = 0.875
13/32 = 0.40625	29/32 = 0.90625
7/16 = 0.4375	15/16 = 0.9375
15/32 = 0.46875	31/32 = 0.96875
1/2 = 0.5	

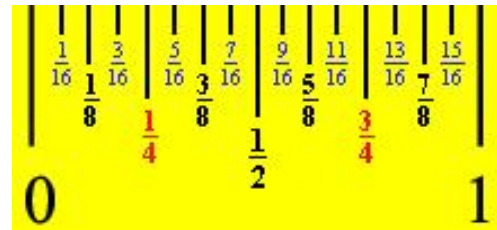

Width = 12 15/16

Height = 24



REAL WORLD EXAMPLE

If a door measures: 12 15/16 inches Wide, by 24 1/2 inches High

Then it should be ordered as: 12.9375 Wide, & 24.5 High

PEEL & STICK REFACE INSTALLATION GUIDE FOR CABINETRY

MEASURING FOR HINGGES

On the door order form you will find a section regarding hinges. This will not be required if you are using exposed hinges. However, if you are using concealed hinges then you will need to order your doors pre-drilled. Remember that your hinge should clear any roll outs or shelves within the cabinet. It is important to note that though all or most of your doors will have the same measurement for hinges, you should check them all to be sure and note any differences on the order form.

To measure for hinges, remove a hinge from an existing door. Measure from the **TOP EDGE** of the door to the **CENTER** of the existing hinge hole. Repeat the process for the bottom hinge.

You will then need to measure the distance from the **SIDE EDGE** of the door to the **OUTER EDGE** closest to the side edge of the door of the existing hole. (See diagram below)

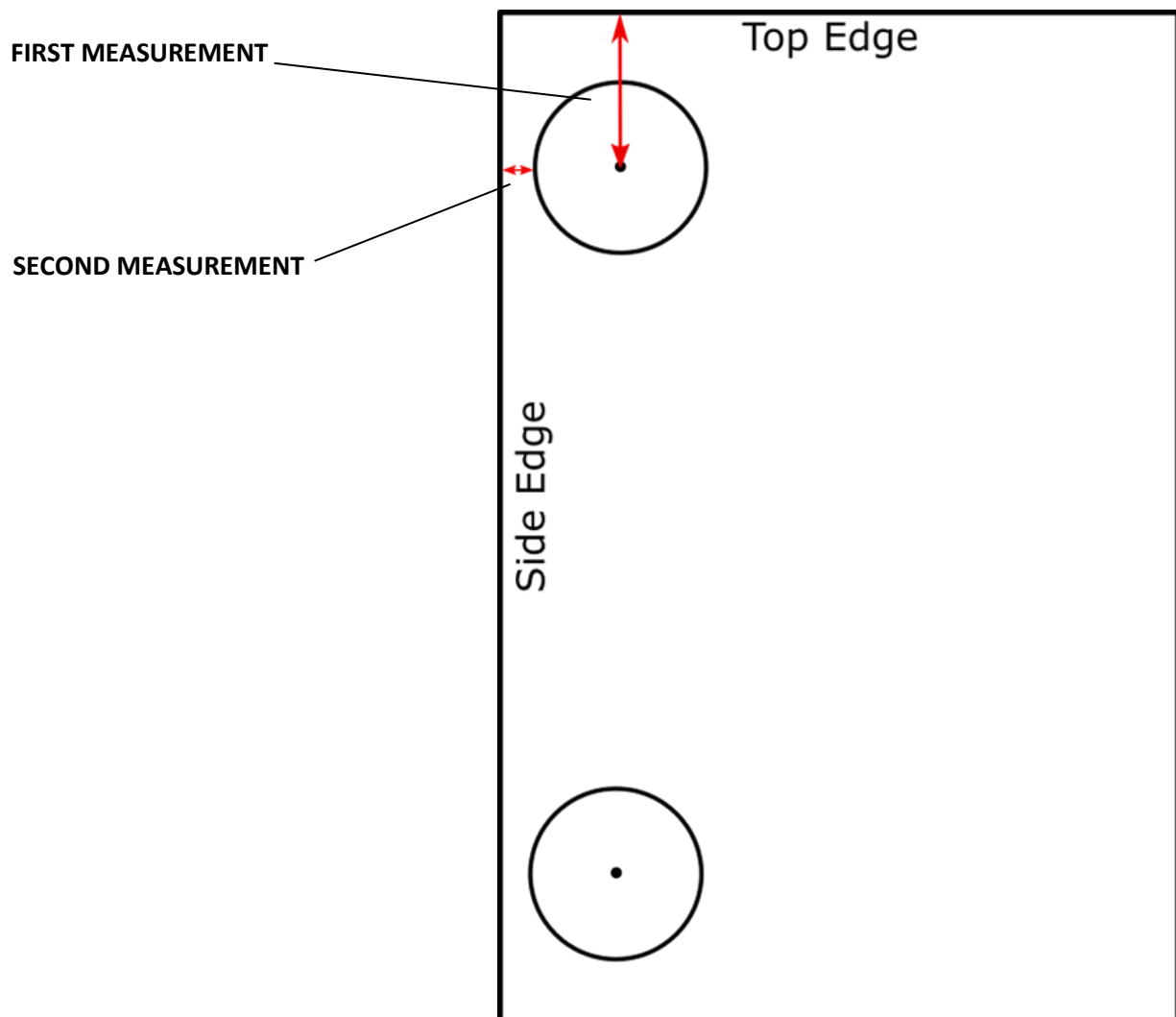

PEEL & STICK REFACE INSTALLATION GUIDE FOR CABINETRY

SECTION 4: PREPARING CABINETS FOR REFACING

EMPTY CABINETS

Before starting any reface project it is always a good idea to empty all of the cabinets. This is a necessary step for two reasons. First, you don't want to risk damaging any contents in the cabinets. Secondly, cleanup will be easier once the job is finished.

Though the thought of emptying out cabinets may seem like a major chore, (and it is), it can also be an opportunity to clean or weed out items you don't need or use anymore. In the long run you will be happy you spent the time to do some reorganizational spring cleaning.

CLEANING

This is one of the most critical steps of the entire reface process. It has and will be said many times in this installation guide that your laminate adhesion is only as good as the surface you are adhering to. Cleaning is the key. Though it is a very easy step in the reface process be sure to take the time to do it well.

You should start by wiping down all laminating surfaces with a damp rag. If you notice any areas that need special attention, (especially dirty), then be sure to scrub them until fully free of residues with a mild soap, like Dawn, and water as needed.

The most important reason for cleaning is to remove ALL grease and oils from the laminating surface. By doing this you will ensure a strong adhesion of the laminate to the cabinet boxes. Remember, the length of time a reface will last depends completely on how well the laminate adheres to the surfaces.

On occasion you may need to use a de-greaser like 409 to remove caked on, or stubborn grease. Be sure to rinse off cleaner residue with a damp rag before laminating as these products are also good at removing adhesives. Allow surfaces to dry completely before you begin the next step in the process.



PEEL & STICK REFACE INSTALLATION GUIDE FOR CABINETRY

LEVELING OF JOINT SURFACES

Sometimes you will have small gaps in between cabinets. You may also have two cabinets where the edges are rounded. In this type of situation you will want to use wood putty or joint filler to fill in the voids. After you fill in the joints and the putty or compound is dry you will want to sand the area smooth. The purpose for this is so that the Peel & Stick laminate won't telegraph the line or void. This process will also work when you have areas with chips or dents.

Be sure to use a wide enough putty knife and a fast drying compound or putty. Here are some products and brands that will work well:



PAD OUTS

Pad outs are necessary for the sides of face frame cabinets because the frame sticks out anywhere from 1/8 to 1/4 of an inch. Though you can technically laminate the panel separate from the frame, you will not be able to laminate the small lip on the back side of the frame that is exposed. For this reason you will want to add a thin panel commonly referred to as a pad out. The panel material itself is sold at any major home improvement store and comes in 4x8 sheets. To save time make sure the panel material purchased comes with at least one side finish grade. This will save sanding time.

The side panel is easy to cut with a skill saw, jig saw, or router. It can be secured to the cabinet with glue like liquid nails and/or a small pin nailer. Sand the joint so as to create a smooth and seamless joint between the filler panel and the edge of the face frame. See diagram below for how the outside edge should look before & after.

Before:

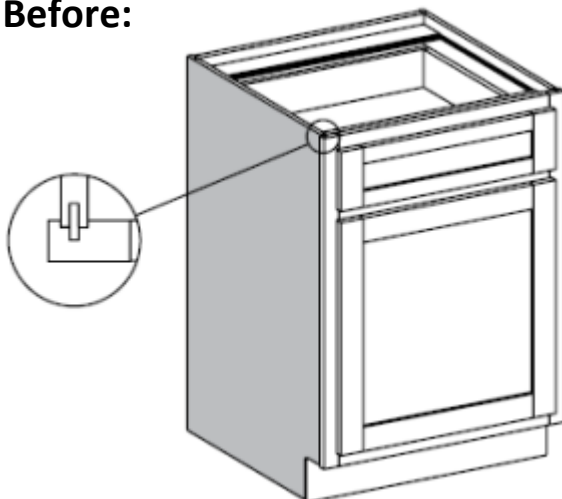

After:

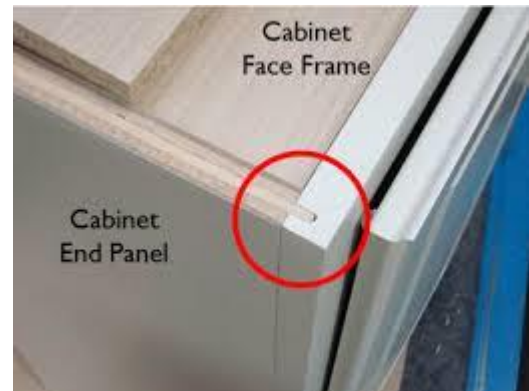

PEEL & STICK REFACE INSTALLATION GUIDE FOR CABINETRY

SANDING OF ADHESION SURFACE



Step 1: Now that the laminating surfaces have been cleaned of dirt & grease it is time to do some light sanding. Using a sanding block, made from a piece of flat scrap wood and wrapped in course grit sand paper, lightly scuff all surfaces that you are about to reface. The reason you need a firm sanding block is so you won't accidentally round any edges. When laminating you want sharp crisp edges for best adhesion. The object here is to rough up any smooth or slick surfaces so a better bond can be formed with an adhesive. Again, this is not a thorough sanding, only a scuffing.



Step 2: For Smoothing out joints or lines it might be easier to use a small palm sander. If you use a sander be sure to use a finer grit paper and keep the sander perfectly flat so as to not round edges or create divots in the adhesion surface. Please note: Divots could telegraph through the laminate so be careful with any sander.



Step 3: (NOT REQUIRED) EXPERTS AT SANDING WITH BELT SANDERS ONLY FOR THIS STEP Though NOT REQUIRED, a belt sander can be used for smoothing surfaces. It should be pointed out that even though a belt sander can save a lot of prep time, it should ONLY BE USED BY INSTALLERS WHO ARE REALLY GOOD WITH A BELT SANDER. If you are unsure if you have the skill to use a belt sander properly on a small surface, then belt sanding is not for you. Take the time to use a palm sander like the one in step 2 until the prep is done. A belt sander has the ability to remove a lot of material really fast and for these reason only skilled sanders who use them all the time should use one to prep for reface.

NOTE: If refacing is part of your occupation. You should consider mastering the belt sander technique as it will pay off in time savings for those refacing on a daily basis.

SECTION 4: PREPARING CABINETS FOR REFACING

APPLICATION OF LAMINATE

You are now ready to start applying laminate to the cabinet boxes. Before you start be sure that your application site is free of dust & debris. Double check that every surface has been thoroughly prepped including sanding, joint filling, de-greasing, & padding. The Peel & Stick laminate will come to you in a roll that is 56-57 inches wide depending on the color. However, only the middle 54 inches is usable. This is because shipping and handling experience has shown that the outer edges take the most abuse when in transit and when handled in the field so it ends up being unusable product any way. Therefore, the edges are not backed with the sticky backing. The white backer paper will need to be peeled back to expose the tacky side. Follow the steps below to determine how to best apply each section of laminate.

PEEL & STICK REFACE INSTALLATION GUIDE FOR CABINETRY

STEP 1: CABINET BOTTOMS (If Applicable)

If during the process of selling (SECTION 2) it was determined that you did not need to laminate the bottom of the cabinets then skip ahead to the next step. However, if you do need to laminate the bottoms they need to be done first.

Unroll the length of material you will need and cut it off with a utility knife. It may be helpful to use a metal yard stick as a guide so you have a nice clean line to start from. Make another cut for your width. To save time add a couple of inches on all sides so you are able to have some overhang. Dry fit the piece to make sure it will fit. Start from the left side bottom and peel a portion of the backer off exposing the sticky back. Starting in the back left corner, start sticking the laminate to the cabinet making sure to fit tight to the back wall. Move from left to right and while removing the backer paper press your hand on the surface as to roll out any air bubbles as you go. Do this until the entire piece is stuck. Make sure that all air bubbles are removed. Once the piece is on securely you will want to trim the excess off (see trimming in the next sub section). Repeat until all of the bottoms are done then move to step 2.

STEP 2: CABINET BACKS & SIDES

If you have exposed backs like on islands or peninsulas you will need to do those next using the same Technique as in step 1 except this time gravity will not be working against you. You will always want to start sticking in the top left corner unless the opposite corner is the only one against a wall (this is the only time it is recommended to work right to left). Again, make sure to press out all air bubbles as you pull back the backer and stick the laminate to the box. You will want to trim off excess after sticking each piece (see trimming in next sub section). Repeat this process until all backs and sides are stuck leaving only the faces to be laminated. Once all backs and sides are faced then you can move to the next step.

STEP 3: FULL FACE

When “Full Facing” a cabinet you will want to cut out a piece of laminate that is large enough to cover the whole area being laminated unless there is an obstacle, like a microwave for instance, in the way. Like before you will want to start at the top and work left to right until the whole piece is stuck (same as sides & backs). Once the piece is stuck you will use your utility knife to cut holes in the open voids. It is recommended that you cut to within a half of an inch to the edge of the void so that the trimmer can be easily used to do the finished trim work.

PEEL & STICK REFACE INSTALLATION GUIDE FOR CABINETS

STEP 4: STYLE AND RAIL

When laminating style & rail in pieces you will want to cut the laminate into strips with room for excess of approximately 1/8th to 1/4 inch on each side. You will want to laminate from the outside in and vertical then horizontal. You will basically follow the same lines existing on the cabinets you are laminating. See Diagram Below:

STEP 1

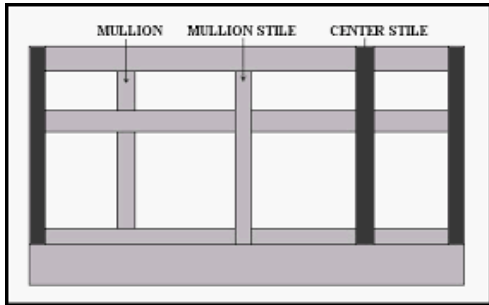

STEP 2

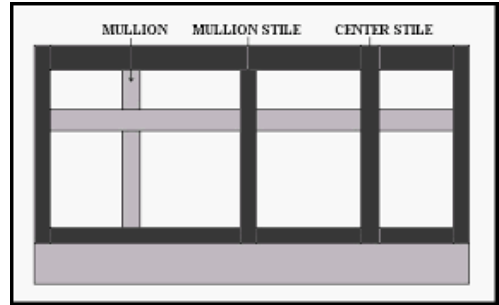

STEP 3

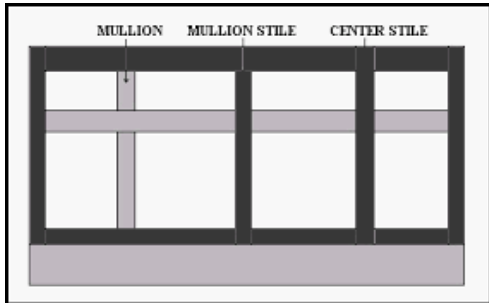

STEP 4



STEP 5

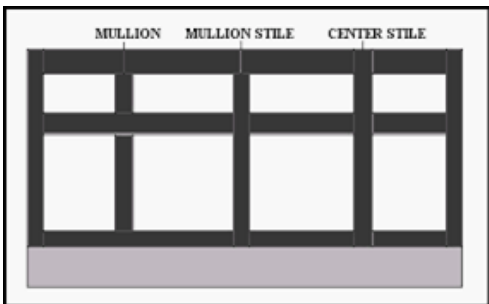

STEP 6

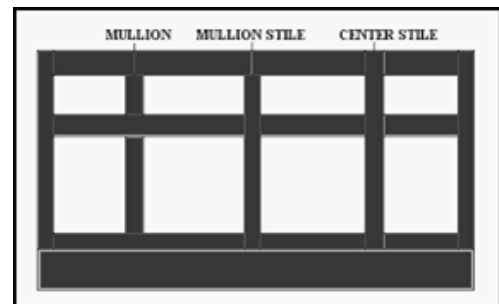

PEEL & STICK REFACE INSTALLATION GUIDE FOR CABINETS

TRIMMING

It is now time to trim! Use utility knife to carefully trim up the inside corners where the Bandit Trimmer can't reach. When trimming overlap, use your utility knife with a small straight edge and score through both pieces of laminate. Remove the excess piece by lifting up the edge of the top piece of laminate and peel up the remaining scrap piece. Then firmly press the pieces onto the adhesion surface. The joint that is left should be almost undetectable.

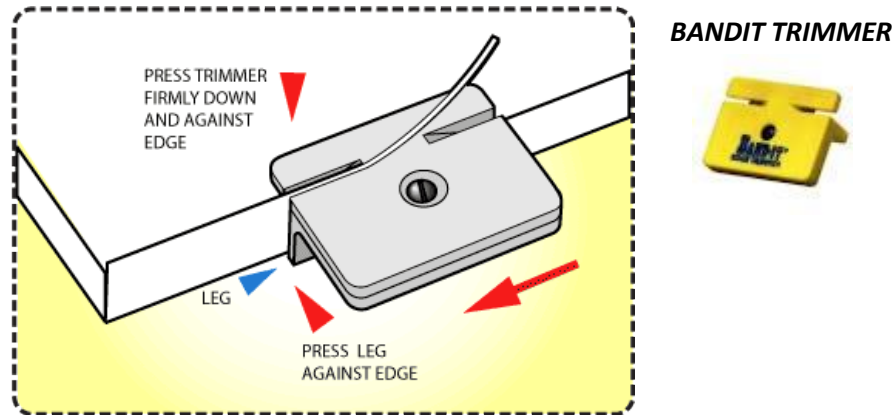

Use utility knife to carefully trim up the inside corners where the Bandit Trimmer can't reach. When trimming overlap, use your utility knife with a small straight edge and score through both pieces of laminate. Remove the excess piece by lifting up the edge of the top piece of laminate and peel up the remaining scrap piece. Then firmly press the pieces onto the adhesion surface. The joint that is left should be almost undetectable.

HOW TO CHANGE THE BLADES

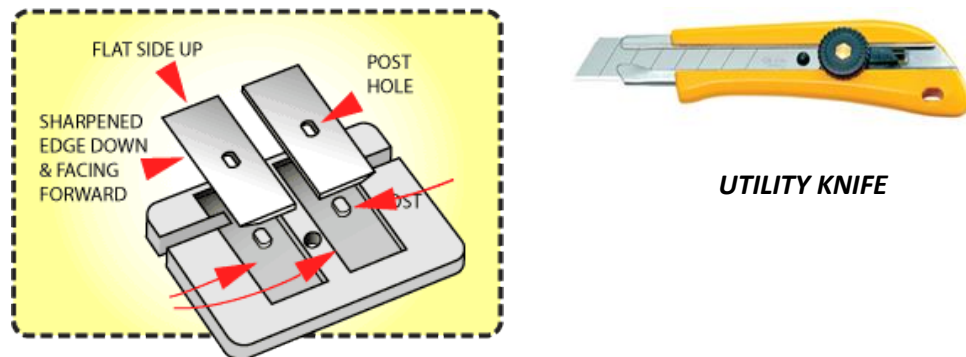

PEEL & STICK REFACE INSTALLATION GUIDE FOR CABINETY

FINISHING OF THE EDGES



You shouldn't need to do very much in this step. If you did a good job of prep and trimming then the edges should stick well and be trimmed flush. However, if you have areas that could be smoother, or areas that could possibly nag, you can use a flat block of wood wrapped in a fine grit sand paper. Be sure the grit is fine and sand lightly, over sanding can result in rounded edges and/or "burn marks" on the adjacent laminate or interior of cabinets.

SECTION 6: DOOR & DRAWER FRONT INSTALLATION

APPLYING HINGES TO DOORS

You will need to apply the hinges to the doors before you hang them. To do this simply place the dowels in the holes and gently tap them in with a hammer or rubber mallet. Then place the hinge into the pre-drilled hole. Next you will screw the hinge to the door and into the dowels. Repeat the process until all of the hinges are properly secured in place.



PEEL & STICK REFACE INSTALLATION GUIDE FOR CABINETRY

HANGING THE DOORS

Face Frame Cabinets

Once the cabinets are hinged you will screw the hinge plate to the cabinet. If you are using existing holes you will want to place a wood toothpick into the existing hole and snap it off flush with the opening of the hole. This trick of the trade will tighten the hole against the screw allowing for a firm grip on the screw. This method is also good to use when the old screw hole is worn out.

If you are not using existing screw holes you will want to extend the hinges to their fullest, then hold the door up with one hand from the top while aligning the door with the other. Make a mark in the center of the screw holes on the inside of the cabinet frame. You can mark the top hinge then fasten it with screws freeing up your other hand or you can mark both top and bottom and secure with screws all at once.

Frameless Cabinets

The same practice applies as above if you are using existing holes. If, however, you are making new holes you will want to use your mini T square to determine how deep into the cabinet to set the holes. Mark a line lightly with a pencil in the approximate location of the hinges. Hold up the door with one hand while lining up the door with the bottom of the cabinet making sure it is sitting flush. Then mark or drill in the center of the hinge plate screw holes.

NOTE: Be sure to place the screws in the middle of the hinge plate screw holes so you will be able to make adjustments later. It is almost impossible to drill two holes right beside each other and have enough support left to hold the weight of the door.

Removal of Old Drawer Fronts

Depending on the cabinet manufacturer, the drawer fronts can be attached a few different ways. It is always advisable to set your T square to the distance between the bottom edge of the old door and the bottom of the drawer before removal. This will ensure the proper horizontal alignment when applying the new front.

Next, remove the pull or knob from the drawer and front. If the front is held on by screws only, just remove the screws and the front should come loose. If the front is still attached then it is likely held on with some kind of glue as well. If this is the case you will want to use a 5 in 1 tool, (see below), and a hammer to carefully break the glue seal.

The possibility exists that the fronts were stapled on. If this is the case you will want to use an old chisel (one you will never use again for its intended purpose), and slowly pry the front of the drawer by working your way around. Once the front is off you will want to break-off or remove the old staples.

PEEL & STICK REFACE INSTALLATION GUIDE FOR CABINETY

Placing New Drawer Fronts

You are now ready to place the new fronts. First, scribe a line in pencil on the back bottom of the new front using the same measurement you set your T square to before removing old front. Next, you will measure the width of the front and subtract the actual width of the drawer and divide that number by 2 to make your markings for the sides. This will make sure that the new front is centered. Then, line your drawer up to the lines you drew and double check with tape measure for accuracy. If the measurements match then, using a powered or cordless drill, screw in 2 course thread screws (one on each side), from the inside front of the drawer. Be sure, when screwing on the doors, that your screws are not too long. You will want to pay special close attention if you are installing a shaker or raised panel front as the front is thinner on the profiled portions. Finally, place the drawer into the hole and make sure the front lines up. If not you can possibly adjust the door to the drawer or remove the new front by removing the screws and make the proper adjustment re-attach the front with screws.

Once all of the doors and drawer fronts are on you will move to the next step which is Hardware.

CHISEL



T SQUARE



SPEED SQUARE



5 IN 1 TOOL



HAMMER



SECTION 7: HARDWARE

MARKING FOR HARDWARE

This is an easy step as long as you pay close attention to what you're doing. Make sure you aren't being distracted when marking your hardware holes because the result is having to re-order a new door. First, layout where your handles or knobs are to be placed. Always use a guide like the one available in the Installation kit from RefaceSupplies.com (see images below). Once you determine the pattern holes to use, start marking the holes with pencil until all the doors and drawers are marked. Make sure you used the right pattern by taking a sample handle around to make sure the hole spread is accurate with the markings on each door. Be sure to check for proper placement at the same time. It can be really easy to accidentally mark a cabinet for handles or knobs on the same side as the hinge. It just takes a moment of distraction. Repeat the pattern until all doors and Drawers are confirmed as properly marked.

PEEL & STICK REFACE INSTALLATION GUIDE FOR CABINETY



Door corner template for handles & knobs. This is included in all installation kits purchased from RefaceSupplies.com.



Mid stile door and drawer front template. This is included in all installation kits purchased from RefaceSupplies.com.

DRILLING FOR HARDWARE

Once you have checked and double checked your hardware markings it is time to break out the drill. Be sure to use a proper size bit (not too big, and not too small) when drilling holes. Use a scrap block of wood to press or clamp behind the hole being drilled so as not to create what is commonly referred to as “blow out” on the back side of the door. This keeps a nice clean hole from door front to door back. Repeat the process until all the holes have been drilled.

After drilling all holes place the hardware on and tighten using a hand screw driver, or a drill with an adjustable clutch so as to not strip out or over tighten the screws. If using a drill with clutch it is wise to set it to slip at mild resistance until you are comfortable with the process.

SECTION 8: THE FINISHING TOUCHES

The finishing touches of the job are very important in determining how the final project will look. There are three main things you **MUST** do before calling the project a wrap. In this chapter we will discuss **Hinge Adjustments, Door Bumper Placement**, as well as job site **Clean-Up**.

HINGE ADJUSTMENTS

Whether you are reusing existing hinges or using new ones, you will need make adjustments to the set screws on the hinges themselves to set the alignment. Some hinges are 3 way adjustable and others are only two way. On the 2 way hinge you can adjust the door so it move up & down as well as side to side. On a 3 way hinge you can also adjust for in and out. This allows you to make sure that one door doesn't sit proud of the door next to it when it is closed. Make sure to familiarize yourself with the range of motion your hinges have prior to adjusting the first one (especially on a long run of cabinets). This will save you a lot of time adjusting and re-adjusting the same hinges over and over.

PEEL & STICK REFACE INSTALLATION GUIDE FOR CABINETS

PLACEMENT OF BUMPERS

RefaceSupplies.com sells door bumpers. These bumpers are made of a clear rubber and are approximately 1/8th of an inch thick. They are to be placed on the outer corners of the back side of each door on the non hinged side. Test closing the door to be sure that where the bumper has been placed is also where the door will touch the cabinet frame or edge.

CLEANUP

Clean-Up is just that, Clean-Up. Be sure to collect all laminate trimmings and laminate protective film and place them in a trash bag. It would not be a bad idea to invest in a small shop vac to use for clean up of small debris and dirt you may have tracked into the home while you were working. Additionally, you should be sure to use a terry cloth to wipe down the cabinets as needed. If for some reason you have places that need a little extra cleaning, you can use denatured alcohol, or mineral spirits, which can be found at any hardware store, to remove most stains like glue residue.

CONGRATULATIONS!!! YOU HAVE NOW SUCCESSFULLY COMPLETED YOUR CABINET REFACE!

DON'T FORGET TO TAKE SOME PHOTOS OF YOUR WORK!

